

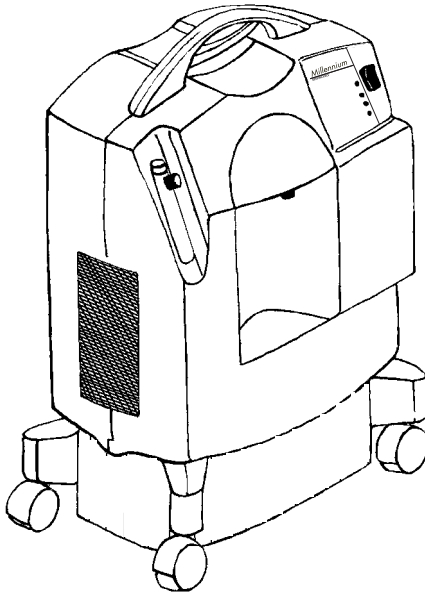

Millennium

RESPIRONICS®

Patient Manual



This oxygen concentrator should be used only under the supervision of a licensed physician. Please read and understand this entire manual before using the device.



Symbol Glossary



No Smoking



CSA/NRTL
ComplianceMark



Attention, consult
accompanying
documents

REF

Model number

SN

Serial Number



Class II equipment



ON (power)



OFF (power)

IPX1

Drip proof
equipment



Type BF applied
part

Classification

The Millennium Oxygen Concentrator is classified as:

- IEC Class II Equipment
- Type BF Applied Part
- IPX1 Drip Proof
- Not suitable for use in the presence of a flammable anesthetic mixture with air or with oxygen or nitrous oxide.
- Continuous Operation

Specifications

Input Voltage:	120 VAC +10%, -15%
Input Frequency:	60 Hz
Average Power Consumption:	460 W
Oxygen Concentration*:	92 ± 4% @ 5 LPM 94 ± 2% @ 2 LPM
Weight:	49.9 ± 0.5 lbs.
Storage/transport temperature:	-30 to 160°F
Operating temperature:	55 to 90°F
Storage/transport humidity:	up to 95%, noncondensing
Operating humidity:	up to 95%, noncondensing
Operating pressure:	10-27 psig
Altitude:	up to 7,500 feet

*Device operation above or outside of the Voltage, LPM, Temperature, Humidity and/or Altitude values specified may decrease oxygen concentration levels.

Covered by one or more of the following U.S. Patents: 5,060,506; 5,183,483; 5,916,349; Other Patents Pending.

Electromagnetic Compatibility

The Millennium is designed to meet the current electromagnetic compatibility requirements. However, if you suspect operation of this device interferes with the normal operation of your TV, radio or other electronic appliance try:

1. Relocating the appliance or the device until the interference stops or
2. Plugging the device into a different power outlet controlled by a separate circuit breaker or fuse.

Important Safety Requirements

Caution! U.S. federal law restricts this device to sale by or on the order of a physician.

Warnings: A warning represents the possibility of harm to the operator or patient

1. For proper operation, your concentrator requires unobstructed ventilation. The ventilation ports are located at the rear base of the device and at the side air inlet filter. Always make sure that these areas are not obstructed by items which may impede ventilation (like blankets, foam, curtains, etc.). Do not place the concentrator in a small closed space (such as a closet).
2. Do not remove the covers of this device. Servicing must be referred to an authorized and trained Respirationics home care provider.
3. In the event of an equipment alarm or if you are experiencing any signs of discomfort consult your home care provider and/or your health care professional immediately.
4. Oxygen generated by this concentrator is supplemental and should not be considered life supporting or life sustaining. In certain circumstances oxygen therapy can be hazardous; any user should seek medical advice prior to using this device.
5. Where the prescribing health care professional has determined that an interruption in the supply of oxygen, for any reason, may have serious consequences to the user, an alternate source of oxygen should be available for immediate use.

6. Oxygen vigorously accelerates combustion and should be kept away from heat or open flame. Not suitable for use in the presence of a flammable anesthetic mixture with air or with oxygen or nitrous oxide.
7. Do not smoke or allow others to smoke or have open flames near the concentrator when it is in use.
8. Do not use oil or grease on the concentrator or its components as these substances, when combined with oxygen, can greatly increase the potential for a fire hazard and personal injury.
9. Do not use the oxygen concentrator if either the plug or power cord is damaged. Do not use extension cords or electrical adapters.
10. Do not attempt to clean the concentrator while it is plugged into an electrical outlet.
11. Device operation above or outside of the Voltage, LPM, Temperature, Humidity and/or Altitude values specified may decrease oxygen concentration levels.
12. Your home care provider is responsible for performing appropriate preventive maintenance at the intervals recommended by the device manufacturer.

Cautions: A caution represents the possibility of damage to the equipment.

1. Do not operate the concentrator without all the filters in place. The filters must be totally dry before operating the device.
2. Do not place liquids on or near the device.
3. If liquid is spilled on the device, turn the power off and unplug from electrical outlet before attempting to clean up spill. Call your home care provider if device does not continue to work properly.
4. Ensure that connections are secure and free of leaks when using the humidifier accessory.

Introduction

Your health care professional has determined that supplemental oxygen is of benefit to you and has prescribed an oxygen concentrator set at a specific flow setting to meet your needs. DO NOT change the flow settings unless your health care professional tells you to do so. The Millennium oxygen concentrator is intended to provide supplemental oxygen to persons requiring low flow oxygen therapy. This device is not intended to be life supporting or life sustaining. The Millennium produces concentrated oxygen from room air for delivery to a patient requiring low flow oxygen therapy. The oxygen from the air is concentrated using a molecular sieve and a pressure swing absorption process. Your home care provider will show you how to operate the concentrator and will be available to answer any questions. You should contact him or her in the future if you have any questions or problems.

Parts of Your Concentrator

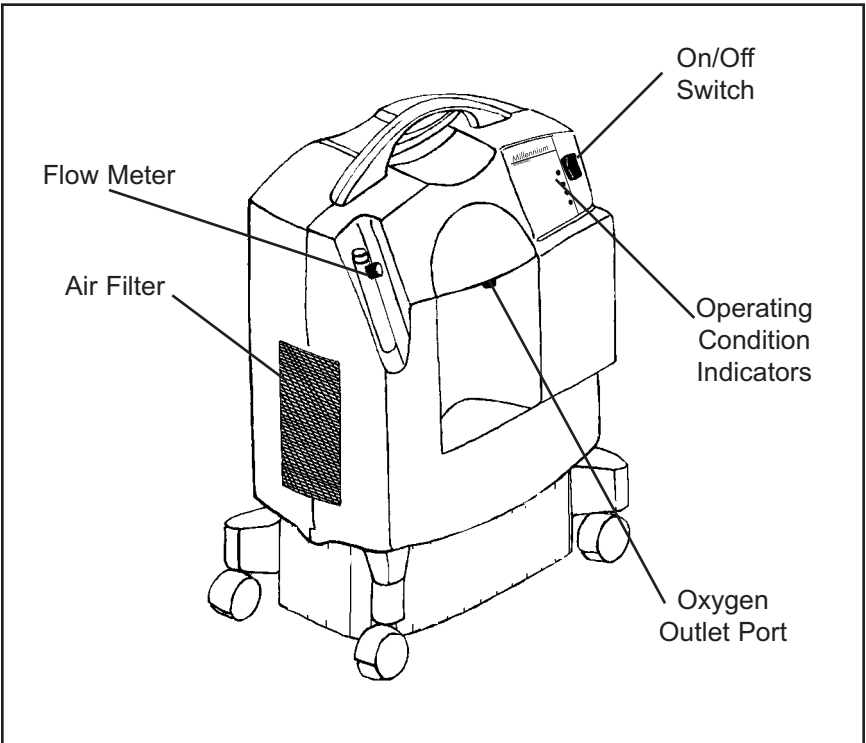

Operating Instructions

1. Select a location that allows the concentrator to draw in room air without being restricted. Make sure that the device is at least 6-12 inches away from walls, furniture, and especially curtains that could impede adequate airflow to the device. Do not place the device near any heat source.
2. After reading this entire manual, plug the power cord into an electrical outlet.

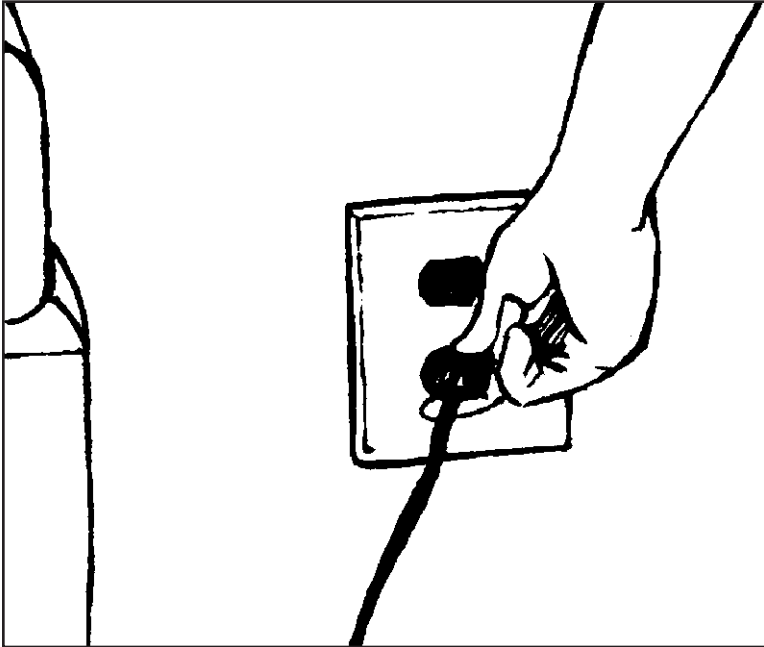

WARNING:
DO NOT USE EXTENSION
CORDS OR ELECTRICAL
ADAPTERS.

3. Connect the oxygen tubing to the oxygen outlet port. If your health care professional has prescribed a humidifier, add water to the recommended level and attach the bottle to the oxygen outlet port. Then attach the oxygen tubing to the humidifier outlet.

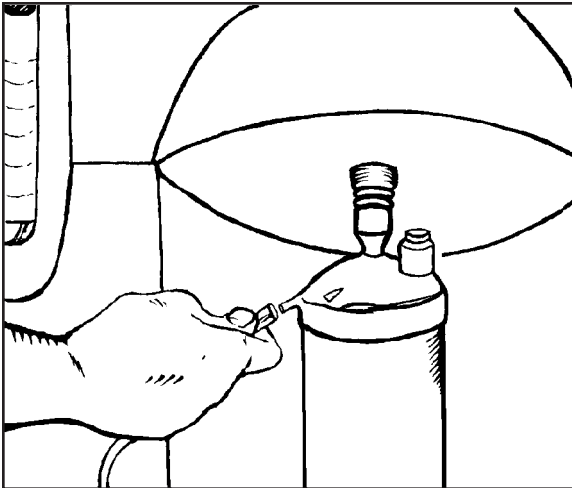
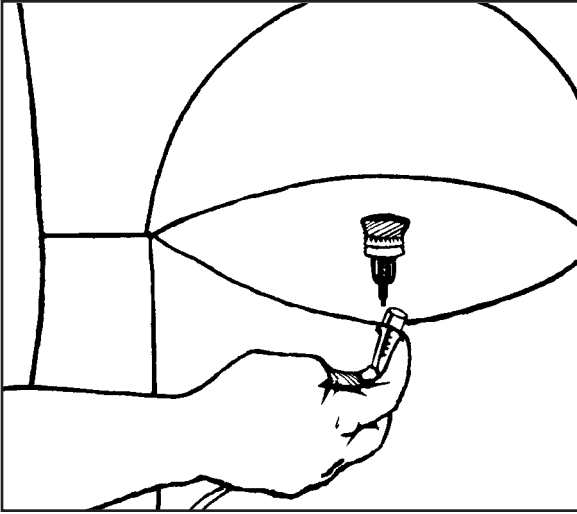

3. Press the power switch to the On [I] position. Initially, all the indicator lights will turn on and the audible alarm will sound for a few seconds. After that time, only the green indicator should remain lit.

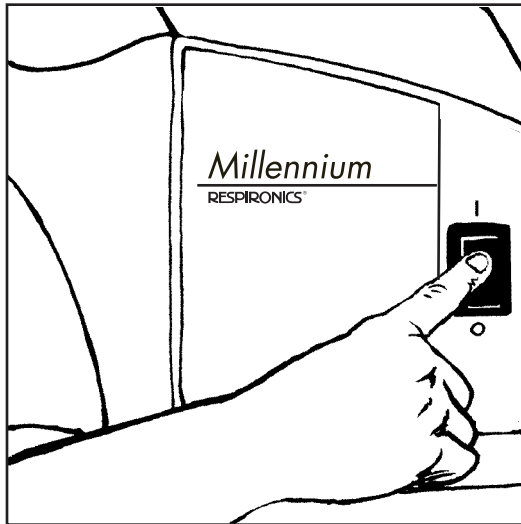

4. After turning on the device, you should allow at least 10 minutes for the device to warm up.
5. Adjust the flow to the prescribed setting by turning the knob on top of the flow meter until the ball is centered on the line marking the specific flow rate.
6. Be sure oxygen is flowing through the cannula or mask. If it is not, refer to the **Troubleshooting** section.
7. Put the cannula or mask on as directed by your home care provider.
8. When not using the device, press the power switch to the Off [O] position.

Accessory Equipment

There are many different types of humidifiers, oxygen tubing, cannulas and masks that can be used with this device. You should contact your local home care provider for recommendations on which of these devices will be best for you. They should also give you advice on the proper usage, maintenance, and cleaning of the accessory equipment.

Maintenance

Warning: It is important to unplug the device before any maintenance or cleaning is performed.

Cleaning and Changing the Air Inlet Filter

Cleaning the air inlet filter is the most important maintenance activity that you will perform and should be done at least once a week.

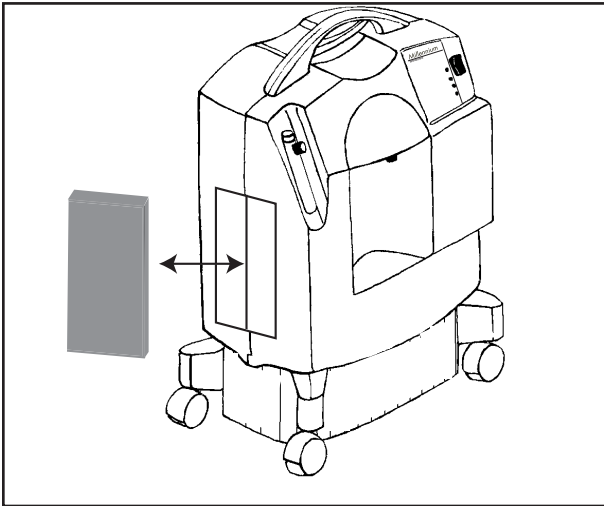

1. Remove the filter from the cabinet.
2. Visually inspect the filter for damage, such as holes or tears.
3. If damaged, replace with a new filter. Contact your health care provider for a new filter if necessary.
4. Rinse and wash the filter in warm water. A mild detergent may be used if rinsed thoroughly.
5. Squeeze out the excess water and allow the filter to air dry. The filter should be completely dry before using again. Excess moisture may impair the proper operation of the device.
6. Visually inspect the filter after cleaning. Make sure it is not damaged or clogged.
7. Reinsert the filter on the cabinet.

Cleaning the Device

You should also clean the exterior case of the device. You may use a damp cloth to wipe down the exterior case. If medical disinfectants are used, be sure to follow the manufacturer's instructions.

Power Interrupt Alarm

If the device is turned on but not operating, the alarm condition will be activated. This is often the result of either the device not being plugged in or a power failure. This feature is powered by an internal 9V battery.

To test the condition of the battery you should test this alarm state often by unplugging the device and switching the power on. If the alarm condition is not activated, you should contact your home care provider to replace the battery.

If the device shuts down because of a power failure, turn the power switch off for two minutes before restarting to allow the system to depressurize itself.

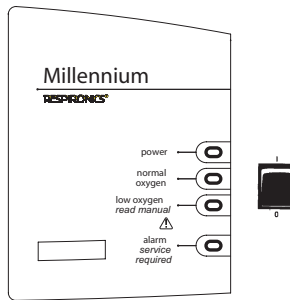

Operating Condition Indicators and Alarms

- **Power:** The GREEN indicator illuminates when the device is turned on.
- **Normal Oxygen** (Model M605 only): The extra GREEN indicator illuminates when the device is delivering a normally expected percentage of oxygen. The illumination of this indicator is delayed for several minutes after start up to allow the system to stabilize.
- **Low Oxygen:** The YELLOW indicator illuminates continuously* to alert the user when some corrective action is required. Following the troubleshooting guide in this manual, this action can normally be performed by the user. Call your home care provider if the troubleshooting actions fail to end this alert condition.
- **Alarm:** The RED indicator illuminates continuously and the audible alarm sounds continuously if the device detects a system malfunction. If this happens when the device is plugged in, you should turn off the device and call your home care professional immediately.

* Units may have intermittent RED indicator and sound an audible alarm accompanying the YELLOW indicator under a Low Oxygen condition.

Minor Troubleshooting Guide

Problem	Probable Cause	Solution
The device is not working when it is turned on; the alarm condition (red light) is activated and the power indicator (green light) is not illuminated.	The power cord plug is not properly inserted into the electrical outlet. No power from the electrical outlet. Internal part failure.	Make sure the device is properly plugged in to the electrical outlet. Check your household outlet fuse or circuit breaker. Contact your home care provider.
Low oxygen (yellow light) activated.*	The airflow to the device is impeded or blocked. The flowmeter knob is completely closed. The oxygen tubing is kinked and blocking the delivery of oxygen.	Check the condition of the air inlet filter and clean or replace as necessary. Remove any items that appear to be blocking the airflow into the device. Turn flowmeter knob counterclockwise to center ball on prescribed LPM Flow. Check to see that the tubing is not kinked or blocked. Replace if necessary.
Alarm condition (red light) activated, when the device is on with the power indicator (green light) on.	Internal system failure.	Contact your home care provider immediately.
Limited oxygen flow to the user.	Faulty oxygen tubing, cannula or face mask. Poor connection of device accessory. Faulty humidifier bottle.	Inspect and replace the items if necessary. Ensure that all connections are free from leaks. Inspect and replace the item if necessary.
Alarm is weak or not sounding when the power cord is un-plugged and power switch is on.	The 9V battery is weak.	Contact your home care provider.

* Units may have intermittent RED indicator and sound an audible alarm accompanying the YELLOW indicator under a Low Oxygen condition.

**PEOPLE
PRODUCTS
PROGRAMS**



RESPIRONICS®
1001 Murry Ridge Lane
Murrysville, Pennsylvania
15668-8550 USA

RESPIRONICS®
Deutschland
Gewerbestrasse 17
82211 Herrsching Germany



1024572
AM 2/25/05